







 12VDC



- 27K  Warm white
Blanc chaud
- 30K  Soft white
Blanc doux
- 35K  Pure white
Blanc pur
- 40K  Cool white
Blanc froid
- BK  Black
Noir
- WH  White
Blanc

LED DEL	Feed Alimentation	Energy used Consommation d'énergie	Light output Flux lumineux	Life Durée de vie	* Angle	CRI IRC
	12VDC	2.5 watts	225 lumens	75000 hours/ heures	90°	90
* According to L70 depreciation standard / Selon le standard de dépréciation L70						

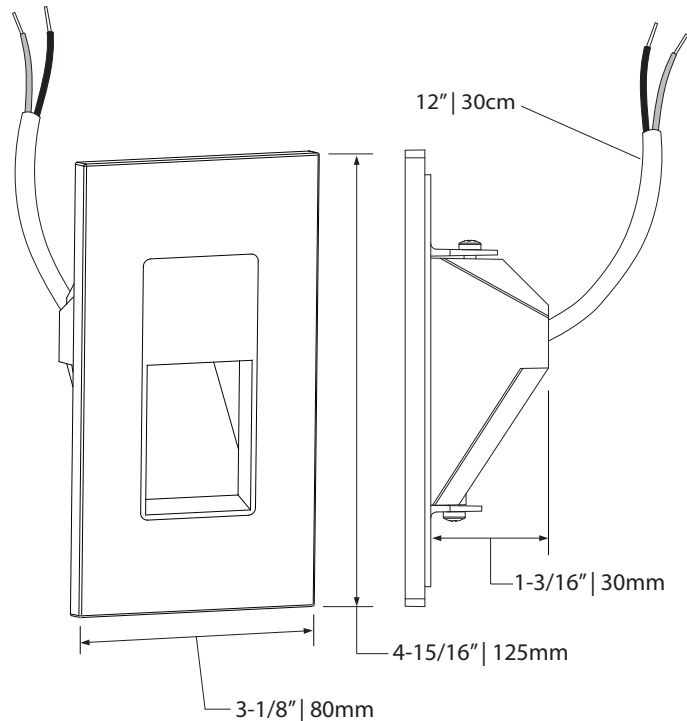

Installs without a junction box
S'installe sans boîte de jonction



Decora wall plate included
Plaque Decora incluse



Certified for *damp location*
Certifié pour *milieu humides*

Product made in Quebec, Canada
Produit fabriqué au Québec, Canada

10 Years warranty
Garantie de 10 ans

Certified for Canada and US
Certifié pour le Canada et les É-U

Recessed depth of 1-3/16" (30mm)
Profondeur encastrée de 1-3/16" (30mm)

Diagonal down light projection
Projection de lumière diagonale vers le bas

Compatible with dimmers
Compatible avec gradateurs

12VDC LED driver required (sold separately)
Pilote DEL 12VDC requis (vendu séparément)



PRODUCT CODE / OPTIONS
CODE DE PRODUIT / OPTIONS

SLD-312X - XXK - PXX

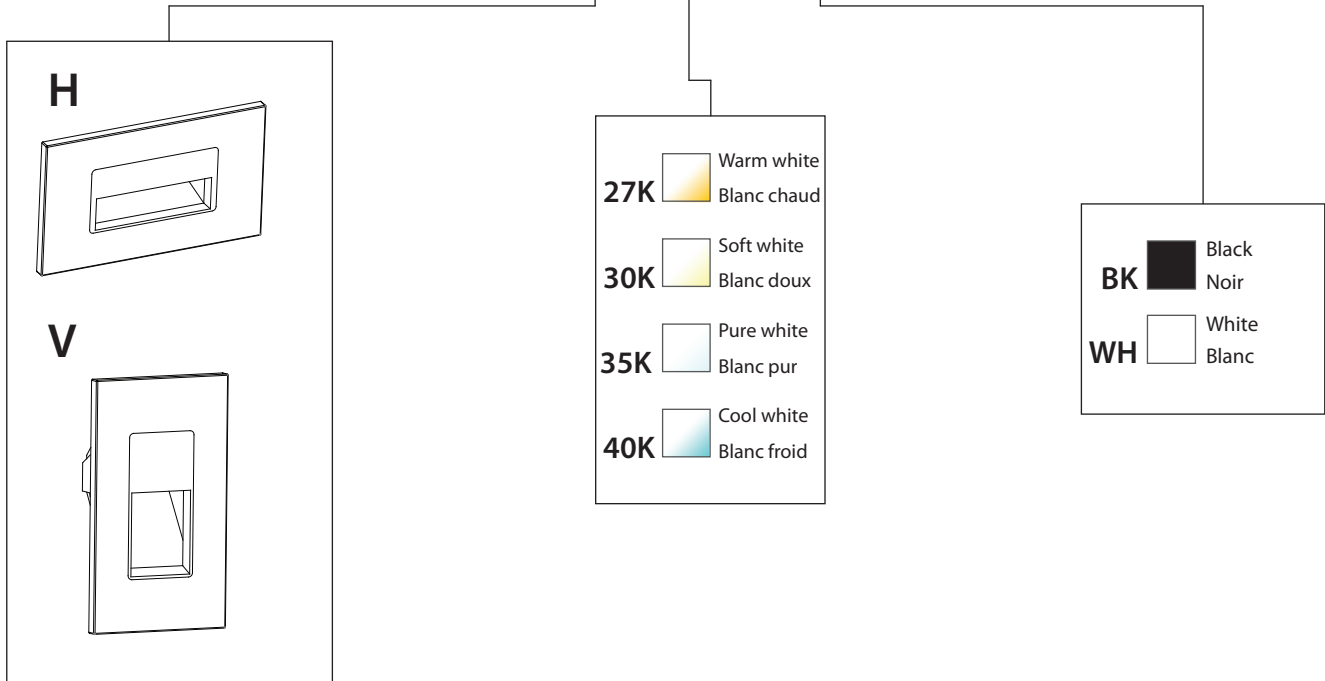

**LIGHT SPREAD
ÉTALEMENT LUMINEUX**

